

SPIKES SYSTEMS

Spike systems are a first security measure used to delay breaching of a vehicle into secured compounds. The systems can be used to create a one-way controlled traffic or as an emergency barrier when security is breached. Our spike systems have the needed flexibility and endurance to work on a daily basis or when needed as an emergency activated barrier. Like all other ELGOTEAM barriers, the spikes can be controlled by any type of operation method existing in the market - buttons, remote, magnetic or proximity cards, LPR and more.

	SPK-01	SPK-02	SPK-03
Product	buried spikes	upper spikes	passive spikes
Operation	pneumatic	pneumatic	-
Foundation Depth	250mm/9.8"	200mm/7.8"	-
Speed	1 sec	1 sec	0.5 sec
Spikes Width/Material	15mm/ST-52	15mm/ST-52	12mm/ST-37
Length(Unit)	900mm/35.4"	900mm/35.4"	900mm/35.4"
Total Length	up to 5 units	up to 6 units	-
Traffic Direction	2 way	2 way	1 way

SPK-01

UP TO 4.5m
(5 Units)

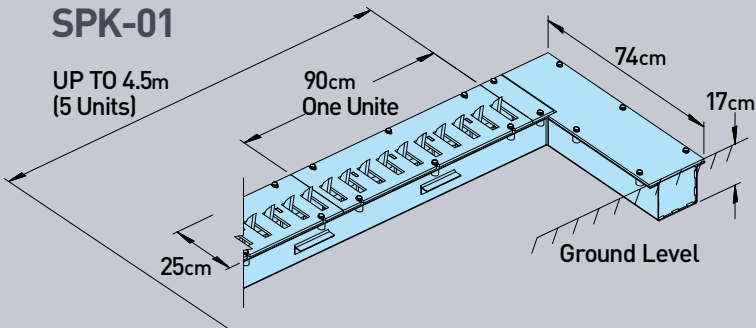

SPK-02

UP TO 5.4m
(6 Units)

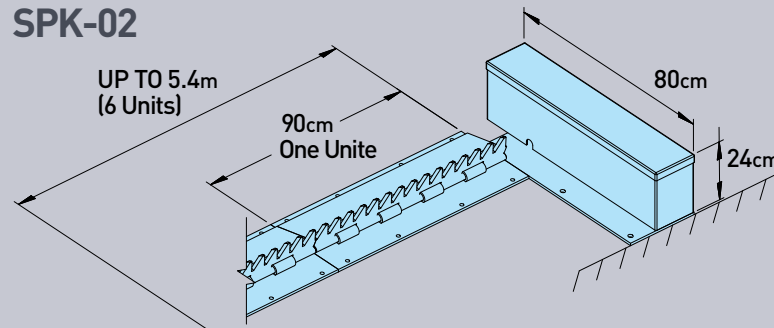

SPK-03

Unlimited

